



POSTMATIC, INC.

INLINE STAMPING BASE-EXTENDED

To accommodate Model 7000SA Stamp Affixer
Parts Manual

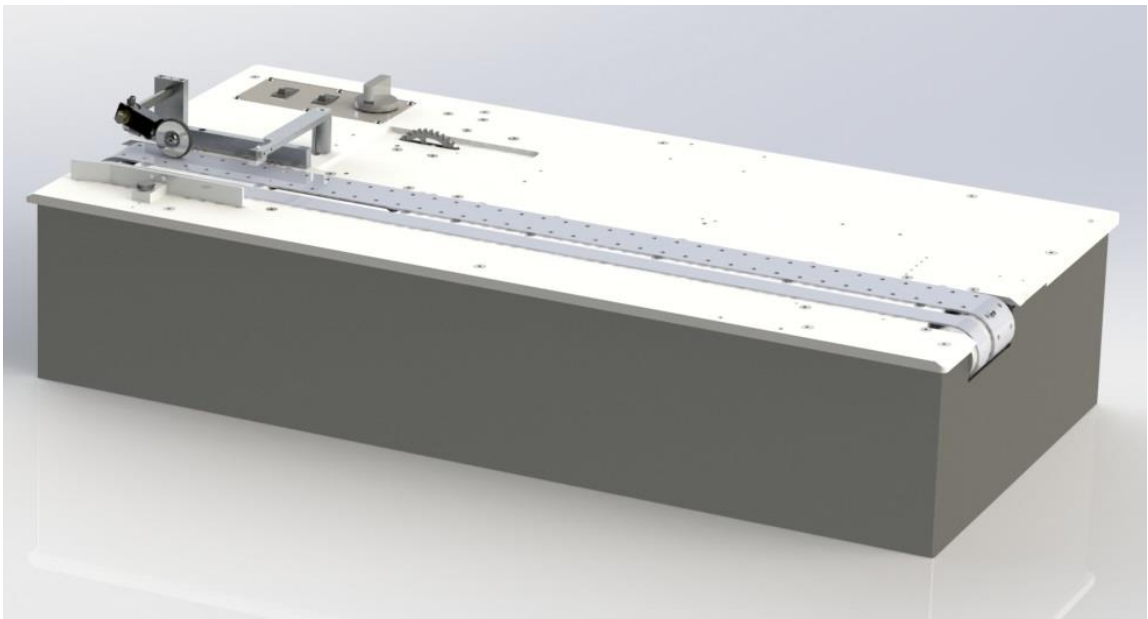

TABLE OF CONTENTS

Inline Stamping Base Extended Assembly

Assembly Table Top Ext M7	2
Assembly Table Top Ext M7 Fig. 1.....	3
Assembly Drive Ext.....	4
Assembly Drive Input	5
Assembly Drive Input Fig. 2.....	6
Assembly Drive Output Ext.....	7
Assembly Drive Output Ext. Fig. 3.....	8
Assembly Clutch Drive M7 Ext.....	9
Assembly Clutch Drive M7 Ext. Fig. 4.....	10
Assembly Vacuum Manifold Ext.....	11
Assembly Plate Switch ISB-Ext.....	12
Assembly Panel Receptacle	13
Assembly Base Plate Ext Components.....	14
Assembly Roller Input Feed.....	15

Assembly Table Top Ext M7

ITEM NO.	PART NUMBER	DESCRIPTION	QTY.
1	300002	PLATE TOP EXT M7	1
2	300019	STAND OFF SENSOR ARM	1
3	1160	8-32 X 3/4 SHCS BLK	2
4	311059	CHASIS MAIN EXT WELDMENT	1
5	300091	BELT TRANSPORT EXT SET 74.75L	1
6	300074	SENSOR PRODUCT INPUT	1
7	1061	5-40 X 1/2 SHCS BLK	2
8	300015	BRACKET SIDE GUIDE ADJUST	1
9	1200	10-24 X 3/4 SHCS BLK	1
10	300017	GUIDE ENTRY ADJUST	1
11	7095	KNOB THUMB SCREW #10	1
12	300113	ASSY ROLLER INPUT FEED	1
13	1115	8-32 X 3/8 FHCS BLK	2
14	300016	GUIDE ENTRY STATIONARY	1
15	300029	SHAFT ROLLER INPUT FEED	1
16	300013	BRACKET RLR STANDOFF	1
17	1165	8-32 X 1-1/4 SHCS BLK	2
18	2010	10-24 X 1/4 SOC SET GIBB	1
19	300018	ARM SENSOR MOUNTING	1
20	1160	8-32 X 3/4 SHC BLK	2
21	1236	1/4-20 X 3/4 FHS BLK	1
22	311065	ASSEMBLY PLATE SWITCH ISB	1
23	1137	8-32 X 1/4 BHCS BLK	6
24	300063	PANEL REAR	1
25	1174	10-32 X 1/4 BHCS BLK	4
26	1177	10-32 X 5/8 FHCS BLK	9

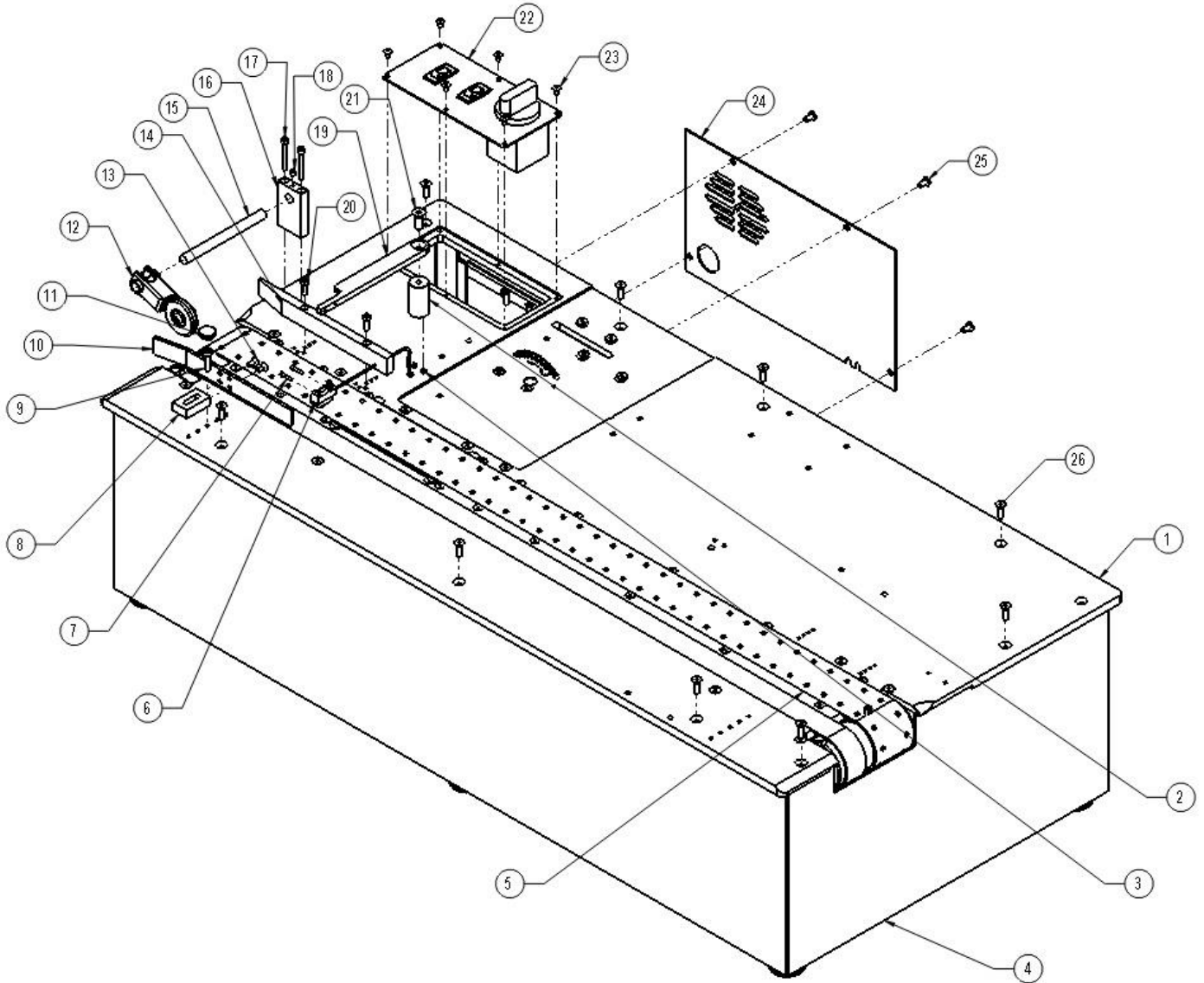
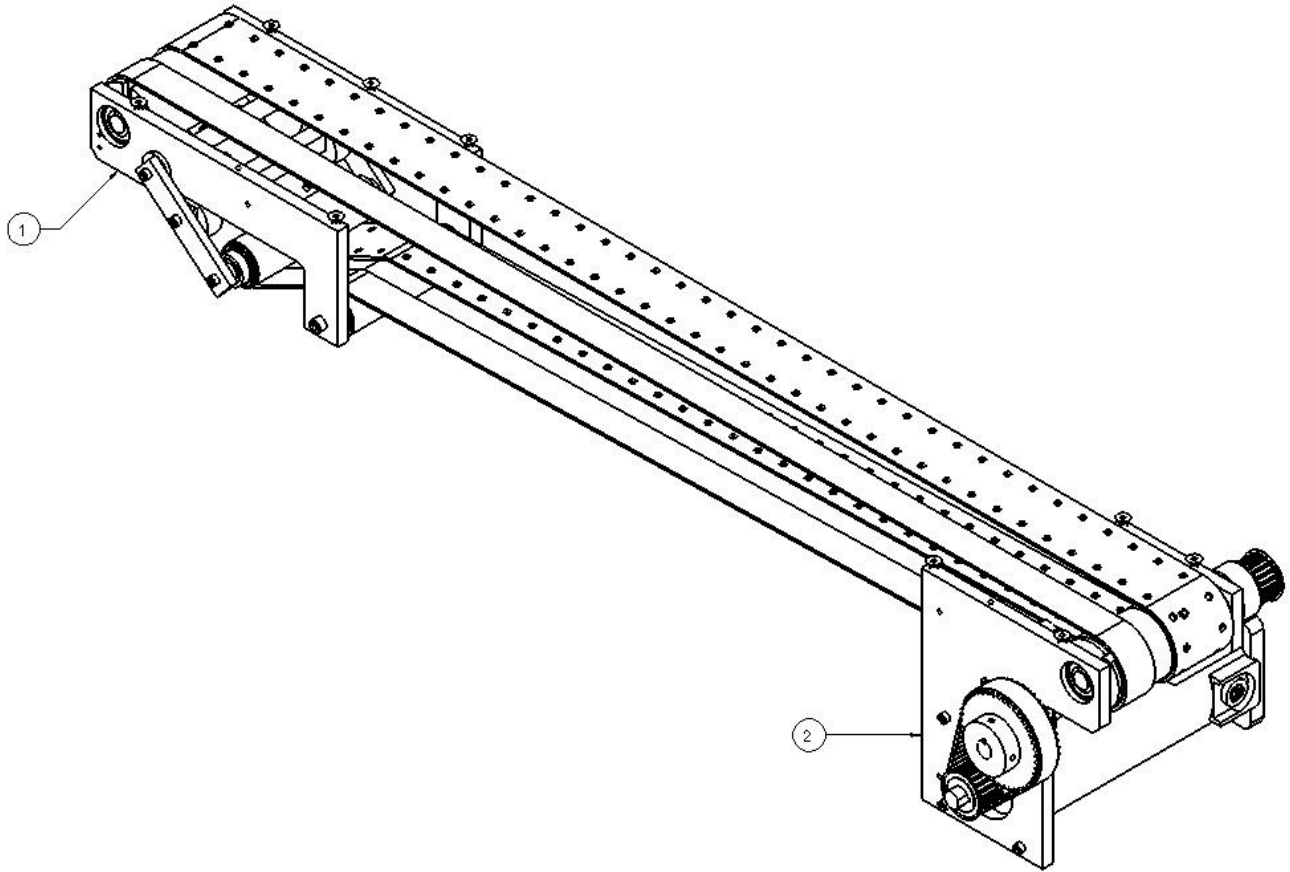

FIG. 1 Assembly Table Top Ext. M7

ITEM NO.	PART NUMBER	DESCRIPTION	QTY.
1	See Fig. 2	DRIVE INPUT SUB ASSEMBLY	1
2	See Fig. 3	DRIVE OUTPUT SUB ASSEMBLY	1



Assembly Drive Ext.

Assembly Drive Input

ITEM NO.	PART NUMBER	DESCRIPTION	QTY.
1	300007	PLATE INPUT LH/RH	2
2	8088	BUSHING FLANGED	2
3	1240	1/4-20 X 5/8 SHCS BLK	6
4	300023	CAM TENSIONER ECCENTRIC	2
5	8225	1/4-20 X 3/4 SHCS BLK	2
6	1245	BEARING SEALED 1/2 X 1-1/8 RNG	2
7	300021	ROLLER BELT TENSION	2
8	300035	SHAFT ROLLER IDLER	1
9	1224	10-24 X 1/4 SOC SET CUP PT BLK	4
10	300008	ARM BELT TENSIONER	2
11	300037	SHAFT CAM MOUNTING SQUARE	1
12	300036	SHAFT PIVOT/ROLLER IDLER	2
13	8224	BEARING 1/2 X 1-1/8 W/ COLLAR	4
14	300038	SHAFT ROLLER DRIVE	1
15	300020	ROLLER BELT DRIVE FLAT	1
16	5040	3/16 X 1-1/2 SPR PIN BLK	1
17	1178	10-24 X 5/8 FHS BLK	4
18	8022	1/2 X 3/4 X .031 SHIM ROUND	4
19	8300*	3/8 O-RING	12

* Not Pictured

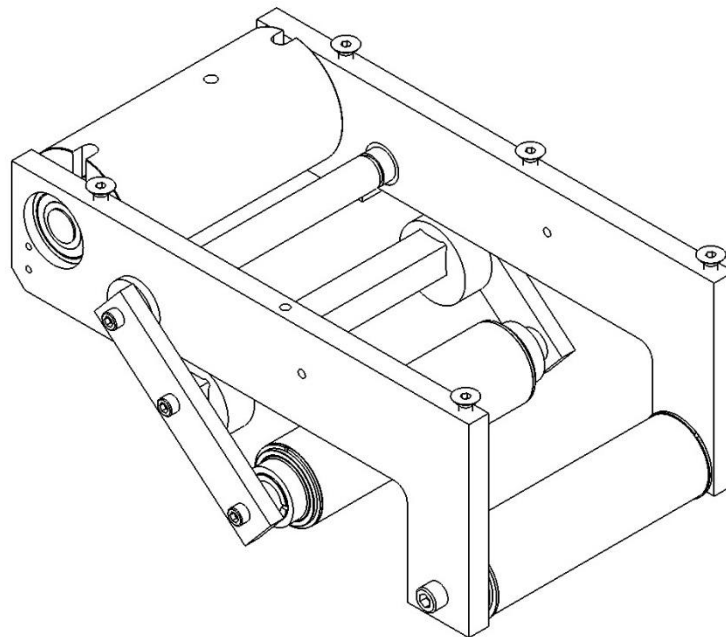
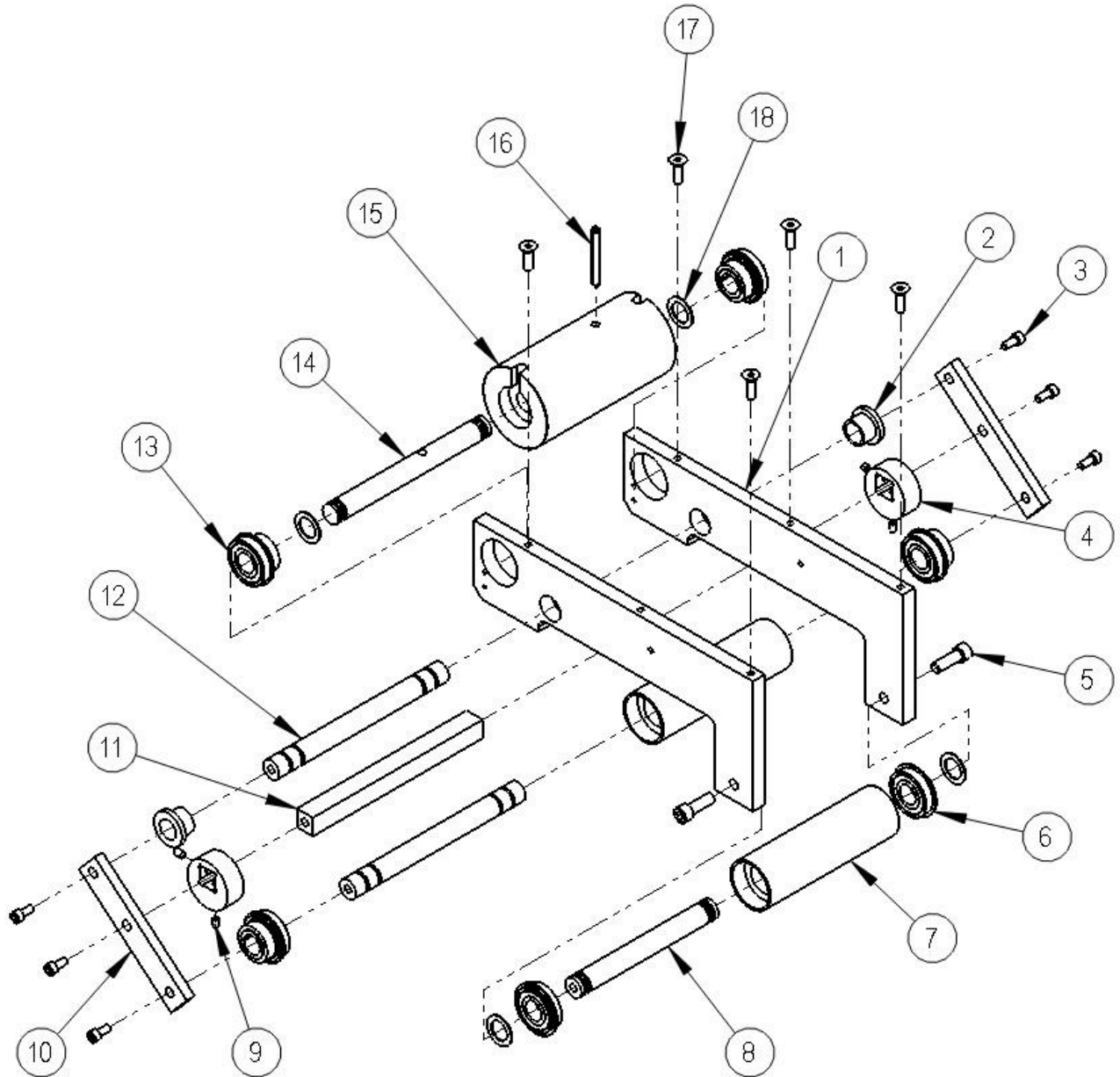
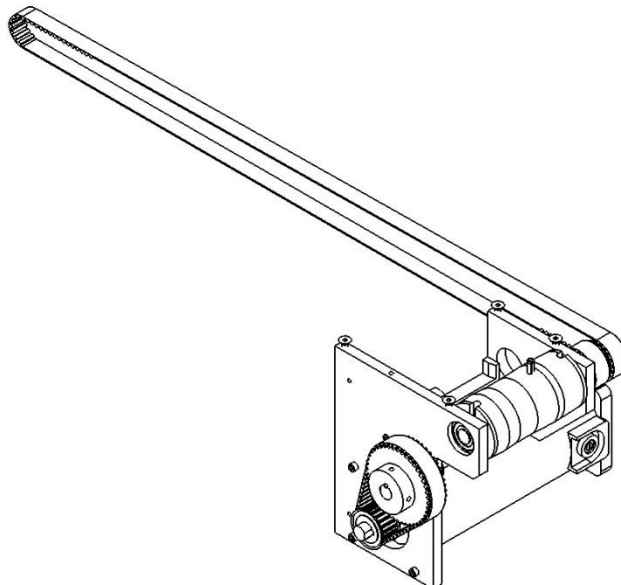

FIG. 2 Assembly Drive Input



Assembly Drive Output Ext.

ITEM NO.	PART NUMBER	DESCRIPTION	QTY.
1	300070	MOTOR DRIVE 90 VDC 1/6 HP	1
2	8225	BEARING 1/2X1-1/8 W/COLLAR	4
3	300030	SHAFT JACK	1
4	300004	PLATE OUTPUT RH	1
5	1250	¼-20 X 1 SHCS BLK	3
6	300052	PULLEY TIMING 20HTD W/ HUB	1
7	300094	BELT TIMING HTD 5M60	1
8	5006	1/8 X 1/8 X ¼ SQ KEY	2
9	300056	PULLEY TIMING 44HTD W/HUB	1
10	1190	10-24 X 1/2 SHC BLK	2
11	300014	BRACKET BELT GUIDE	1
12	8022	½ X ¼ X .031 SHIM ROUND	2
13	1178	10-24 X 5/8 FHCS BLK	4
14	300032	SHAFT ROLLER DRIVEN	1
15	300022	ROLLER BELT DRIVE CROWNED	1
16	5040	3/16 X 1-1/2 SPR PIN BLK	1
17	300054	PULLEY TIMING 22HTD MACHINED	1
18	300510	BELT TIMING HTD 5M254	1
19	5007	1/8 X 1/8 X 1-1/4 SQ KEY	1
20	300051	PULLEY TIMING 18HTD W/O HUB	2
21	300093	BELT TIMING HTD 5M51	1
22	8023	½ X ¼ X .093 SHIM ROUND	6



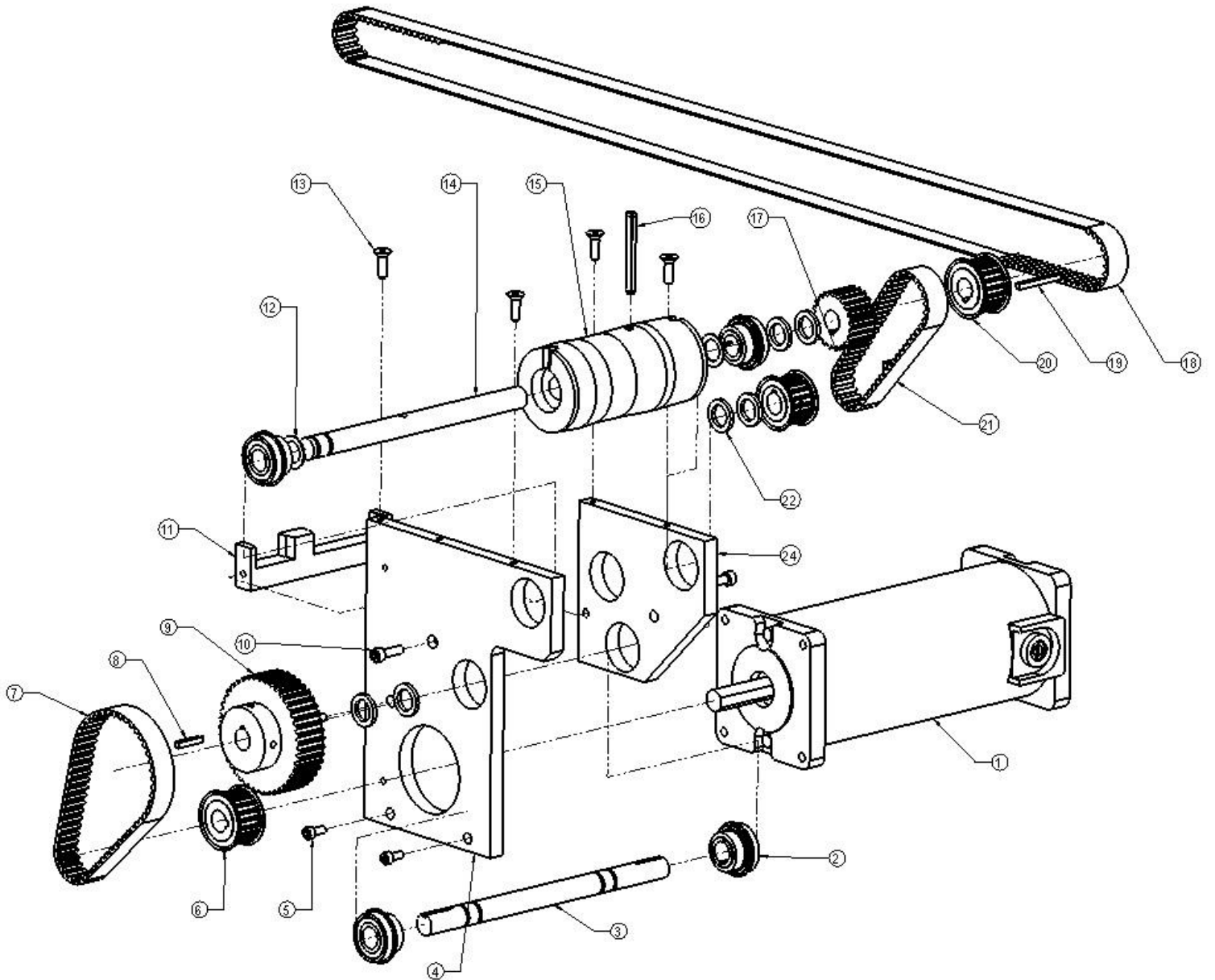

FIG. 3 Assembly Drive Output Ext.

Assembly Clutch Drive M7 Ext.

ITEM NO.	PART NUMBER	DESCRIPTION	QTY.
1	300505	PLATE CLUTCH SHAFT EXTENDED	1
2	8220	BEARING SHEILDED R6-5ZZ	1
3	1176	10-32 X 1 BHSC BLK	3
4	300006	PLATE GEAR SHAFT	2
5	8225	BEARING ½ X X 1-1/8 W/COLLAR	4
6	700015	GEAR HUB	1
7	1230	¼-20 X ½ SOC SET KC	1
8	600024	DRIVE GEAR	1
9	1177	10-32 X 5/8 FHCS BLK	2
10	5015	3/16 X 13/32 SQ KEY	1
11	5006	1/8 X 1/8 X ¼ SQ KEY	2
12	300034	SHAFT GEAR DRIVE	1
13	300055	PULLEY TIMING 22HTD W/HUB	1
14	1184	10-32 X 5/8 SHCS BLK	1
15	300005	PLATE CLUTCH SHAFT	1
16	300026	TENSIONER BELT .400"	1
17	8205	ROLLER BEARING R-6 DBL SEAL	2
18	300092	BELT TIMING HTD 5M46	1
19	300054	PULLEY TIMING 22HTD MACHINED	1
20	5069	3/8 GRIP RING	1
21	300033	SHAFT CLUTCH	1
22	300071	CLUTCH WRAP SPRING 1-STOP	1
23	1137	8-32 X ¼ BHCS BLK	2
24	300097	PAD CLUTCH CUSHION	1
25	3048	3/8 X 1-1/4 SHOULDER BOLT	1
26	8024	3/8 X 5/8 X .125 SHIM ROUND	1
27	300050	PULLEY TIMING 30 HTD CL W/O HUB	1
28	8206	BEARING 3/8 X 7/8 W/RING	2
29	300508	PULLEY IDLER 22HTD	1
30	5069	3/8 GRIP RING	2
31	300506	ARM BELT TENSIONER	1
32	1178	10-24 X 5/8 FHCS BLK	6
33	1245	¼-20 X ¾ SHCS BLK	1
34	1180	10-24 X ¾ FSH	2
35	8300*	3/8 O-RINGS	9

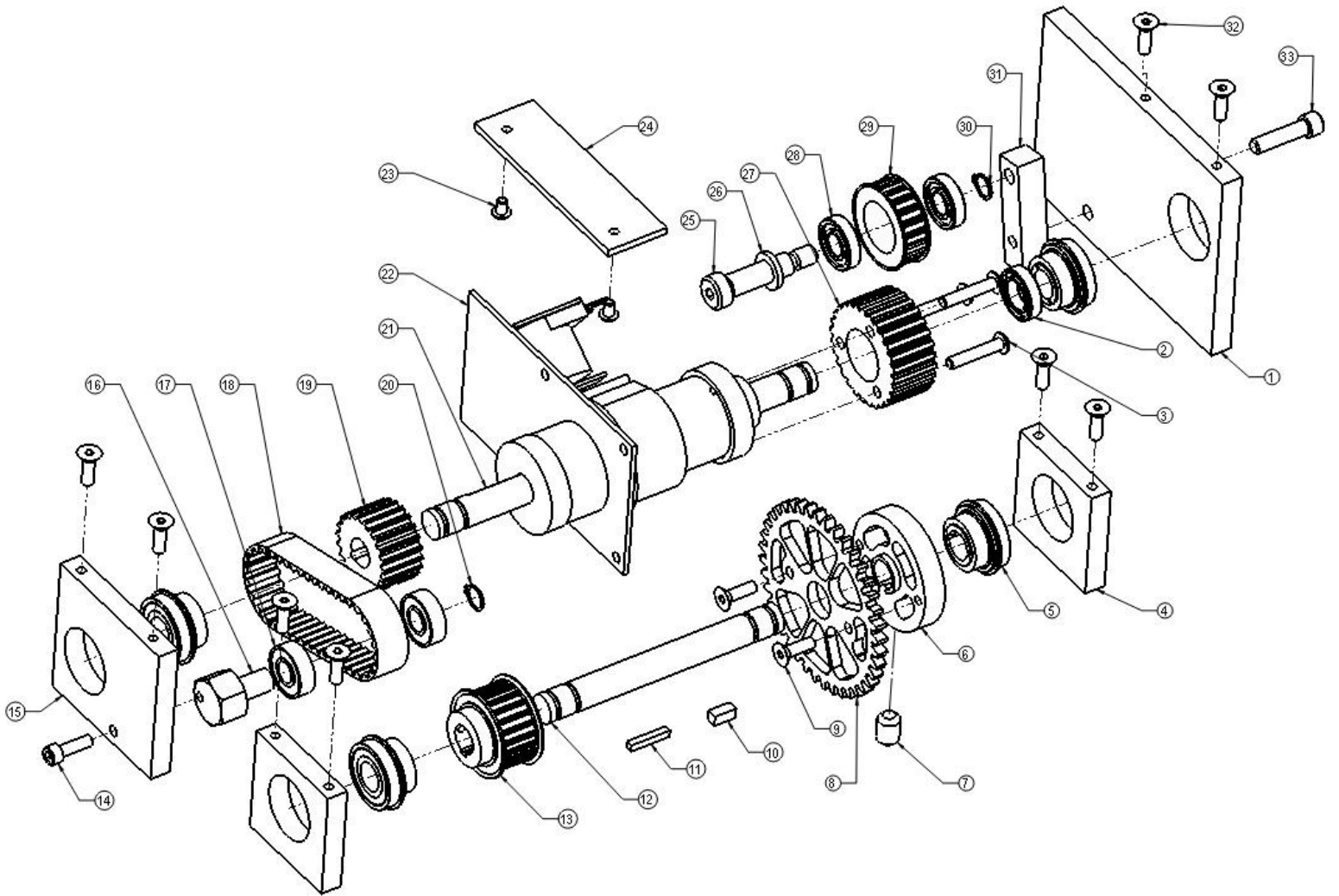

FIG. 4 Assembly Clutch Drive M7 Ext.

Assembly Vacuum Manifold Ext.

ITEM NO.	PART NUMBER	DESCRIPTION	QTY.
1	300009	PLATE VACUUM MANIFOLD	1
2	300044	PIPE 3/4 PVC 3.0"L	2
3	300041	PIPE ELBOW 45 DEGREE 3/4 PVC	1
4	300046	PIPE 3/4 PVC 2-1/8" L	1
5	300047	TUBE PVC CLEAR 1" X 3-3/8"L	1
6	300043	PIPE 3/4 PVC THREADED 2-1/2" L	1
7	300040	PIPE ELBOW 90 DEGREE 3/4 PVC	1
8	1220	10-24 X 3/8 BHCS BLK	8
9	1125	8-32 X 5/8 FHCS BLK	16
10	300011	PLATE VAC MANIFOLD EXT	1
11	300010	PLATE MANIFOLD INLET	2
12	300045	PIPE 3/4 PVC THREADED 13"L	1
13	300039	PIPE T 3/4 PVC	1
14	300042	PIPE 3/4 PVC THREADED 3-3/4"L	1

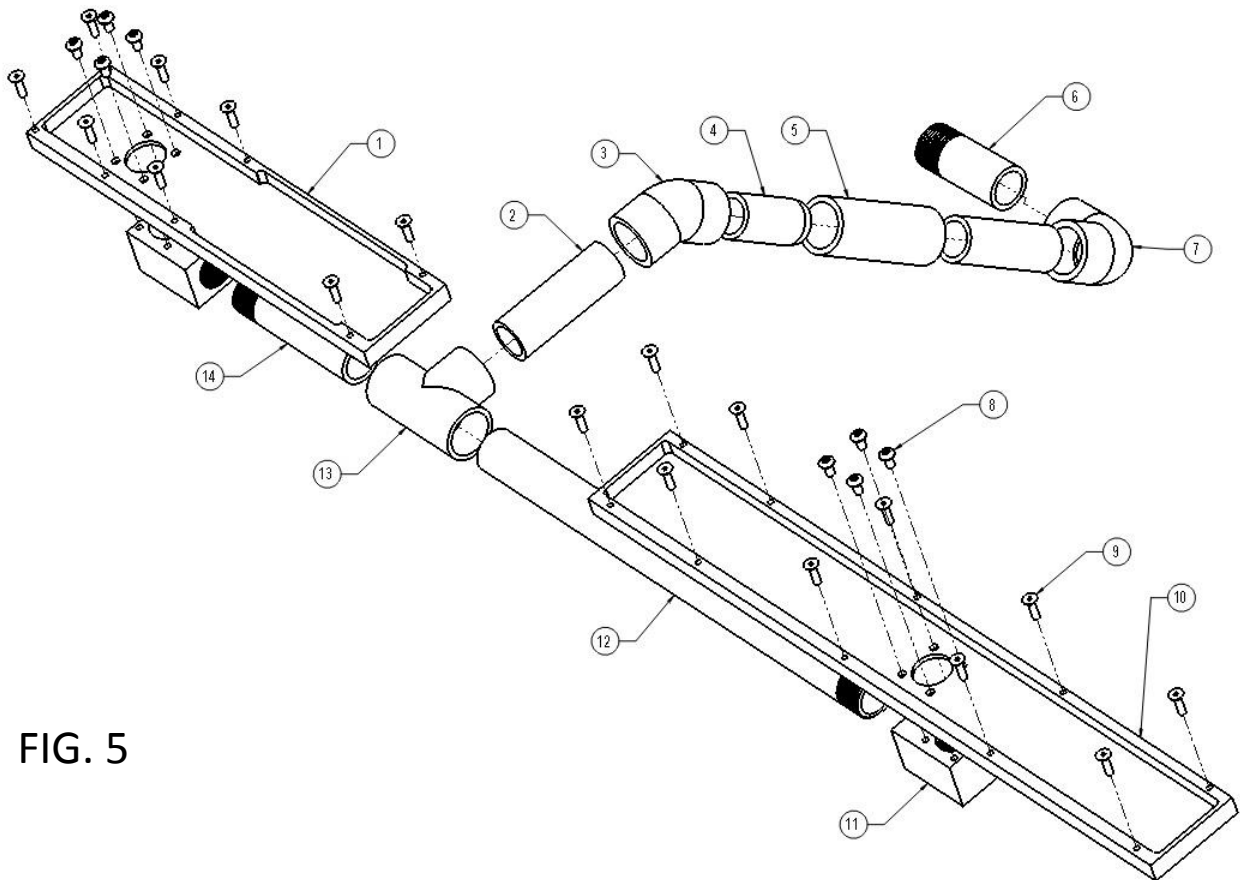

FIG. 5

311065 Assembly Plate Switch ISB Ext.

ITEM NO.	PART NUMBER	DESCRIPTION	QTY.
1	300065	PLATE SWITCH ISB	1
2	300085	SWITCH SPEED SELECT 3/POS	1
3	100515	SWITCH ROCKER ON/OFF	2

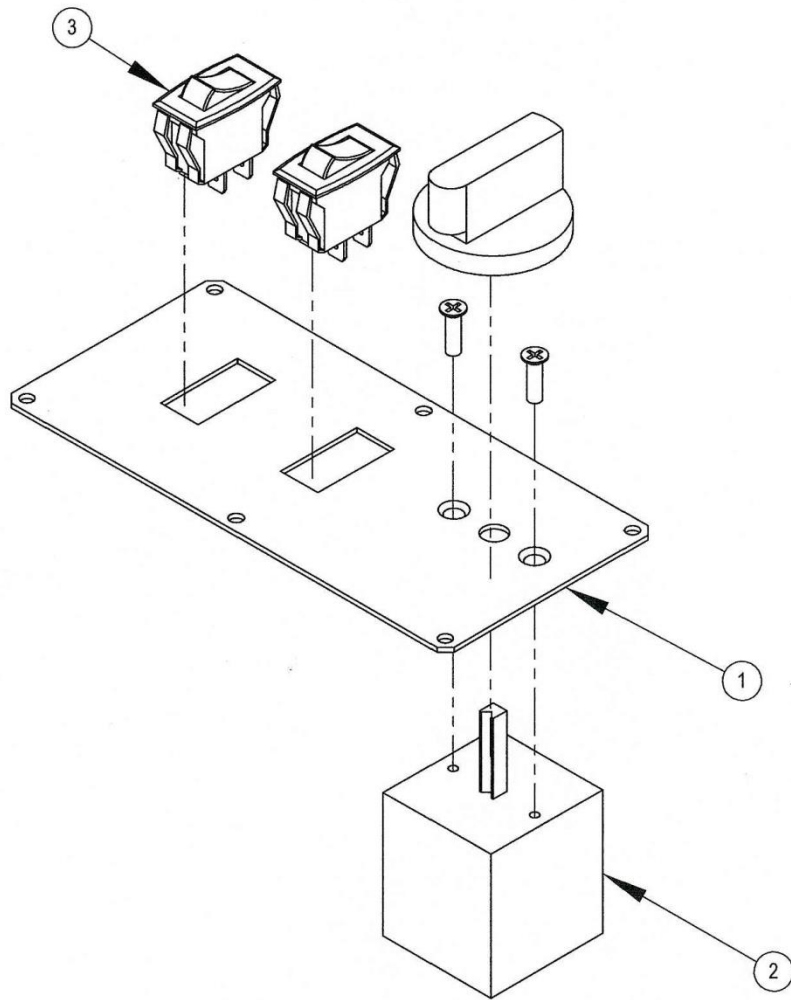

FIG. 6

Assembly Panel Receptacle

ITEM NO.	PART NUMBER	DESCRIPTION	QTY.
1	300064	PANEL RECEPTICLE	1
2	300080	INLET AC W/SWITCH	1
3	1174	10-32 X 1/4 BHCS BLK	4
4	300081	HOLDER FUSE PANEL MOUNT	2
5	100522	FUSE GLASS 5 AMP	1
6	100523	FUSE GLASS 10 AMP	1
7	300083	OUTLET POWER AC	2

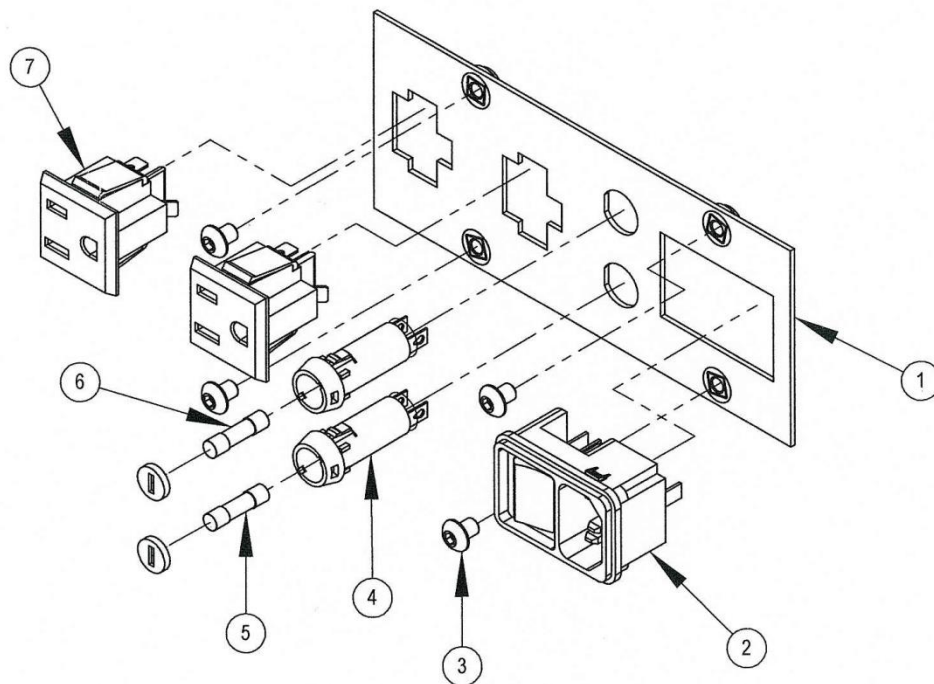

FIG. 7

Assembly Base Plate Ext. Components

ITEM NO.	PART NUMBER	DESCRIPTION	QTY.
1	300072	MOTOR BLOWER FUJI 115VAC	1
2	300058	BRACKET WIRE HARNESS PLUG MTG	1
3	300077	ASSY WIRE HARNESS MALE/FEMALE	1
4	300073	CONTROLLER MOTOR DRIVE DC	1
5	300084	BLOCK TERMINAL SURFACE MOUNT	1
6	300075	POWER SUPPLY 27VDC	1
7	300095	FOOT LEVELING 3/8-16 X 1-1/2	6
8	4049	3/8-16 NUT JAM Z	6
9	1150	8-32 X 3/8 SHCS BLK	6
10	1160	8-32 X 3/4 SHCS BLK	2
11	300076	BOARD ASSY CLUTCH INTERFACE	1
12	8008	1/2 AL STAND OFF RND	2
13	1082	6-32 X 5/8 SHC BLK	2
14	1155	8-32 X 1/2 SHCS BLK	2
15	1280	3/8-16 X 3/4 BOLD W/ LOCKING FL	2

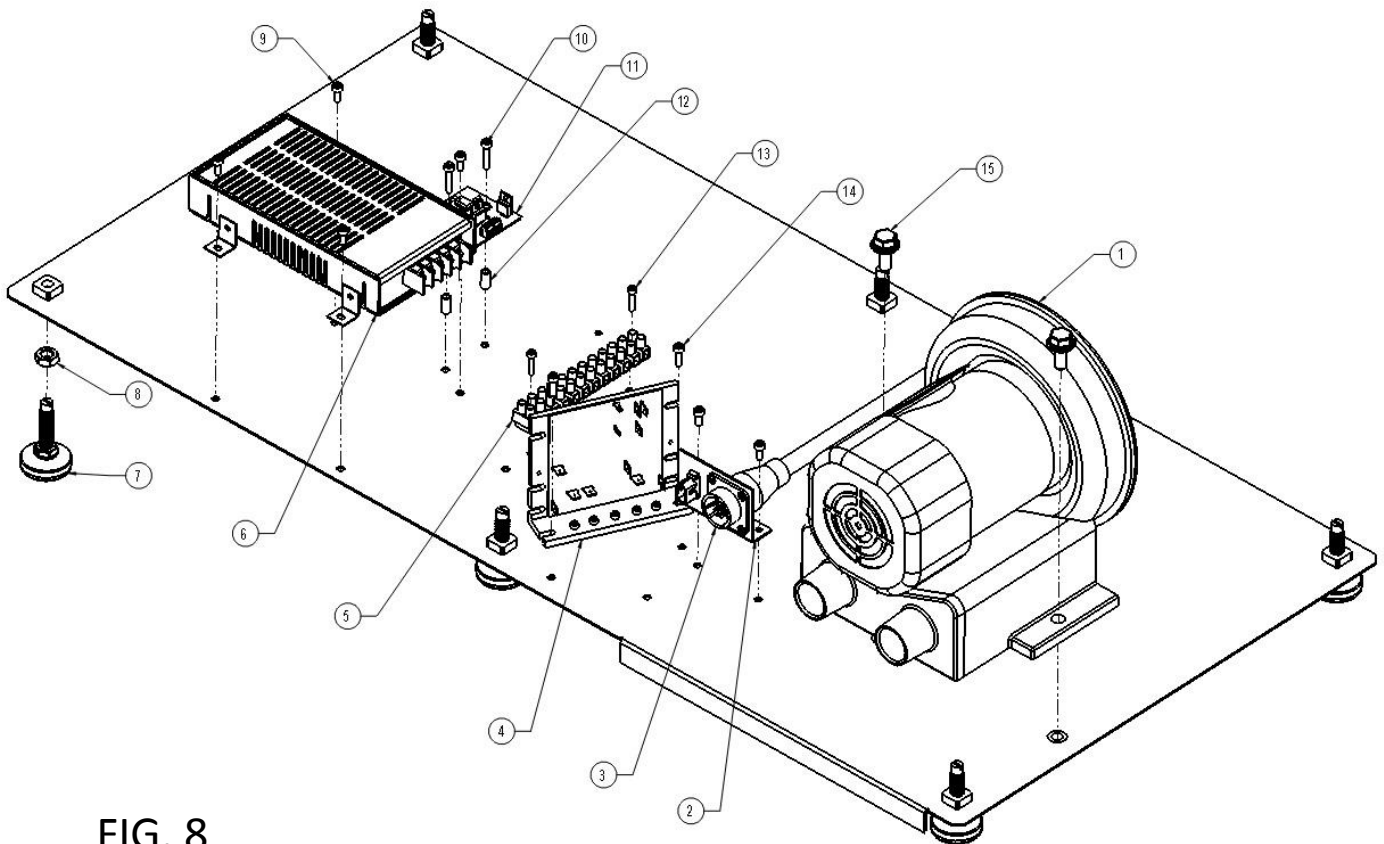

FIG. 8

Assembly Roller Input Feed

ITEM NO.	PART NUMBER	DESCRIPTION	QTY.
1	300116	ARM ROLLER INPUT FEED	1
2	300117	BUSHING ARM INPUT FEED RLR	2
3	4060	¼ WASHER Z	1
4	4061	¼ WASHER LOCK Z	1
5	8203	BEARING ROLLER R-4 DBL SEAL	1
6	300118	ROLLER INPUT FEED	1
7	1233	¼-20 X 5/8 BHCS BLK	1
8	1138	8-32 X 3/8 BHCS BLK	1
9	300115	COLLAR INPUT FEED ROLLER	1
10	1226	¼-20 X 3/8 SOC SET FP	1
11	300114	SPRING EXTENSION	1
12	300119	O-RING SQUARE INPUT FEED RLR	1
13	4020	8-32 NUT Z	1
14	4040	¼-20 JAM NUT Z	1
15	300029	SHAFT ROLLER INPUT FEED	1

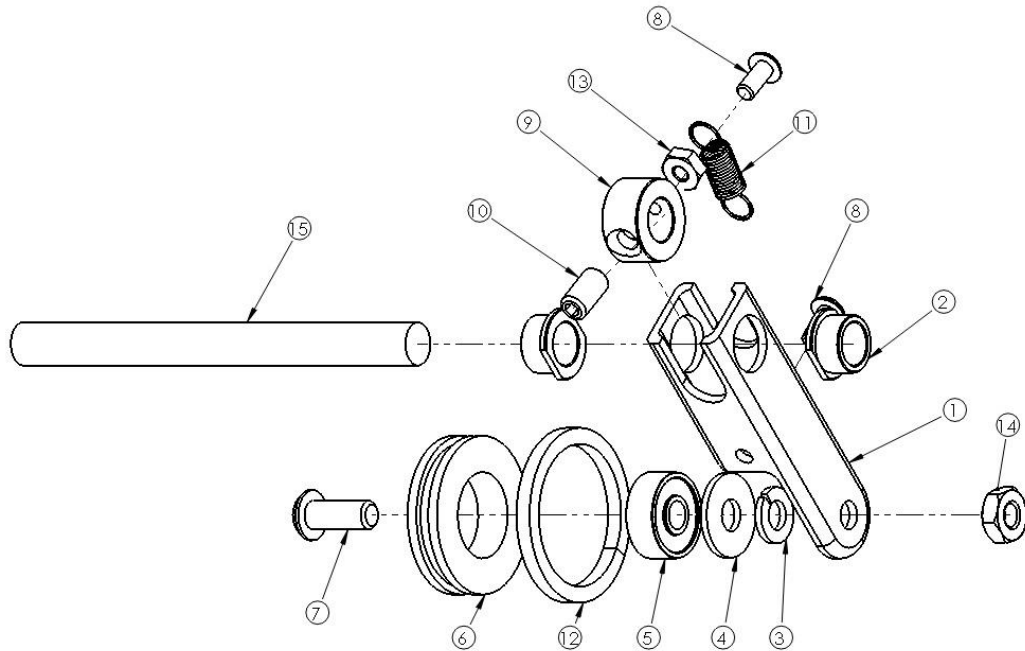

FIG. 9